



## 1. Shipping addresses

Address:

Gebr. FALLER GmbH

Kreuzstrasse 9  
D-78148 Gütenbach, Germany

Phone: +49 7723 651 0

Fax:+ +49 7723 651 161

Logistics Centre:

Haas Logistic GmbH  
Lager Gebr. FALLER GmbH

Härdtnerstraße 2  
D-78655 Dunningen

Phone: +49 7406 9211 0

Fax: +49 7406 9211 55



## 2. Delivery / Notification

Deliveries are accepted at the following times:

Gebr. FALLER GmbH

Mon – Thu

7:30 – 9:15 a.m. and

9:30 a.m. – 12 p.m. and

1 p.m. – 4 p.m.

Fri

7:30 – 9:15 a.m. and

9:30 a.m. – 12 p.m.

Phone: +49 7723 651 538

Haas Logistic GmbH:

Mon – Fri

8 a.m. – 12 p.m. and

1 p.m. – 4 p.m.

Phone: +49 7403 9211 0

## DELIVERY INSTRUCTIONS



AA 04-07-02-00

Version 003/Date 14/01/2021

---

### Notification:

#### Gebr. FALLER GmbH

For more than six pallets,  
please notify us one day in advance.

Phone: +49 7723 651 538  
Email: [h.burger@faller.de](mailto:h.burger@faller.de)

#### Haas Logistic GmbH:

We must be notified of all deliveries at least one day before! For more than six pallets, please notify us two days in advance. Not sending notification of delivery may result in waiting times or not being allowed to unload – at the expense of the sender.

Phone: +49 7403 9211 0  
Fax: +49 7403 9211 55  
Email: [faller@haas-logistic.de](mailto:faller@haas-logistic.de)

### 3. General delivery requirements

- Basic pallet dimensions:  
1,200 x 800 mm delivery on Euro pallets  
Goods placed on the pallet must not overhang the pallet edge.
- Load height:  
1,800 mm max. (including pallet)
- Max load per pallet:  
Gebr. FALLER GmbH: 1,000 kg (including pallet)  
Haas Logistic GmbH: 1,000 kg (including pallet)
- Pallet secured with wrap film for safe transport
- Individual items are shrink-wrapped or inside a cardboard box
- Any deviations in delivery must be agreed in advance (such as exceptions for securing the load).
- If a small vehicle (e.g. van) is used for delivery that has a loading sill measuring of less than 1.10 m, the driver must unload the goods himself/herself.

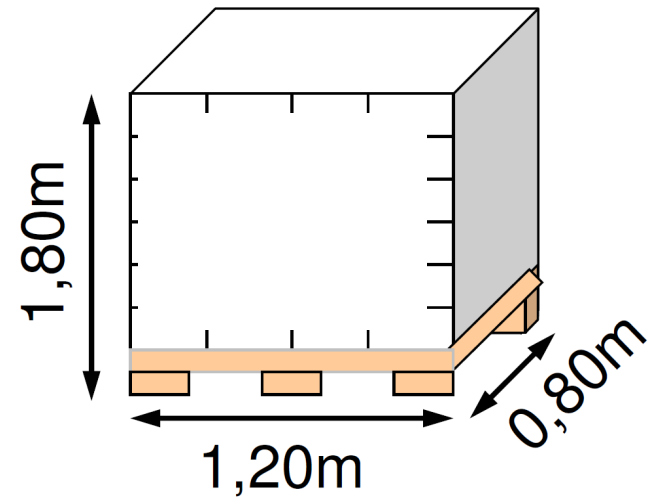

## 4. Pallet for pallet exchange

The delivery must be made on Euro pallets that are in perfect shape according to the European Pool Pallet standard. These will be exchanged in the incoming goods department. If the same number of empty pallets is not in stock, they will be returned or offset within a reasonable amount of time. In this case, the driver will be given a pallet receipt for the difference in quantity. Pallets will only be returned with the presentation of the original pallet receipt at the place it was issued.

The following pallets cannot be exchanged:



A board is broken sideways or at an angle.



A block is rotten, decayed or is severely splintered.



A block is missing or split open in such a way that more than one nail is visible.



More than two bottom deckboards or top deckboards are chipped in such a way that more than one nail shank or screw shank is visible.



A bottom deckboard or top deckboard is chipped in such a way that more than one nail shank or screw shank is visible.

Please note that for each pallet that cannot be stored, a flat rate of **EUR 40.00 plus tax** will be charged.



## 5. Checking the consignment

Consignments are accepted subject to certain conditions. The driver is only given a receipt for the time being for the number of delivered packing units (colli, pallets, etc.). Quantities and articles are checked at a later date with the help of the delivery note. We have the carrier confirm any external damage to the consignments on the consignment note and delivery note.

## 6. Delivery note

In addition to the consignment note, each consignment must include a delivery note. The following information is required:

- Exact shipping address (see 1)
- Supplier, delivery date, recipient
- Exact article number and name
- Total number of items per article
- Number of pallets per article
- Number of items per pallet
- Order number
- Each packing unit (e.g. carton) must be labelled (content, quantity)
- Loose goods must be packed in cartons
- All cartons must be closed



## 7. Labelling packaging units

If FALLER/POLA finished products are delivered in packaging units (PU), each PU master carton must have a PU label. Label information can be provided by FALLER. This label contains the following information:

- Article number
- Name (4 languages)
- Quantity (PU)
- Content volume of the PU
- Batch number optional
- EAN barcode (14 digits)

Example of a PU label:





## 8. Master carton goods labelling

If FALLER/POLA finished products are delivered, all the master cartons must have a content label. This label contains the following information:

- Article number
- Name
- Box content quantity
- EAN barcode
- Batch number optional
- for PU: total number of items inside the master carton

Example of master carton labelling for “items” contents:



Example of master carton labelling for “PU” contents:







Label information can be provided by FALLER.

Dangerous goods must be labelled in accordance with the legal regulations as amended (each master carton with dangerous goods label, UN no., LQ and “this side up” arrows).

All the above-mentioned labels must be clearly legible and affixed to the outside of the master carton and the pallet!

If these points are not observed, an hourly rate of **EUR 30.00 plus tax** will be charged for the time and effort incurred.

## 9. Customs clearance

All shipments from abroad must be delivered duty paid. Duty unpaid consignments must be reported before delivery and must be marked as such.

## 10. Unloading the truck

At delivery, pallets must be loaded in such a way that the truck can be safely unloaded from the rear with the help of forklift trucks. The goods must be freely accessible and must not be blocked or overloaded with goods of third parties. Side unloading is generally not possible. In the event of major unloading problems, it is to be expected that we may refuse to accept the delivery.