

 CAR SYSTEM

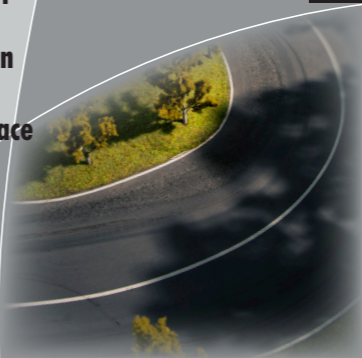


161677
Branch-off junction

161675
Stop section

161674
Parking space

EN



Instruction Manual



Content

1.	Welcome to the world of FALLER	3
2.	Safety and responsibility	5
3.	Branch-off junction, Art. 161677	9
4.	Stop section, Art. 161675	23
5.	Parking space, Art. 161674.....	36
6.	Interesting facts	48
7.	Technical data and symbols.....	55

1. Welcome to the world of FALLER

With FALLER Car System components you will be able to reproduce nearly any desired traffic scenario easily and reliably on your model installation. Control components »Stop section«, »Branch-off junction« and »Parking space« will allow you to operate several vehicles simultaneously, while reliably contributing to traffic safety. Along with simple stops and right-of-way rules, more complex traffic sequences such as bus stops, bottlenecks at road construction sites or stays at petrol stations can also be implemented.

The components being installed below the roadway, they are always invisible to the beholder. They also are scale neutral, that is, the mounting procedure and the required space are identical for track gauges N and H0.

Whenever you want to install any component, observe the position and dimensions stated in the present instruction manual as accurately as possible, and particularly make sure that all roadway surfaces are level. To ensure heat dissipation each component should be installed so as to feature a clearance of approx. 10 mm in all directions.

The easiest way to activate components is to connect them to a FALLER control module. In Car System Digital operation components are controlled through the software. In analog operation Sensors (Art. 161773) built into the roadway transmit a signal to a control module whenever a vehicle passes over them. Whenever a control module activates a component the vehicle is steered towards a guide wire turning off or the current supply to the motor within the vehicle is switched in such a way that said vehicle will drive on or stop. For this purpose each vehicle is provided in the right half of the underside of its chassis with a dry-reed sensor, or with a magnetic field sensor in the case of digital vehicles.

You will find suggestions, ideas and detailed wiring diagrams for instance in the instructions for use supplied with control module »Traffic Control« (Art. 161651). Of course components can also be activated manually via a control panel or using push buttons or switches available from electronics retailers' shops.

2. Safety and responsibility

Proper use

Car System components »Stop section«, »Branch-off junction« and »Parking space« are exclusively designed for use on a model installation. You will be able to select and combine the functions of these components and to adapt them to your specific requirements. To ensure the reliable operation of all components it is imperative that the present instruction manual and the recommendations given on road building in FALLER brochures be followed.

The guarantee offered will not apply to any damage or defect resulting from the non observance of the directions given in the present instruction manual.

For your safety

- ▶ Carefully read through the present instruction manual before using the products.
- ▶ Pay attention to the safety recommendations and warnings given in this instruction manual or provided on the products.
- ▶ Inform children of the contents of the instruction manual, if necessary, and of the potential hazards related to the use of the products.

- ▶ Let children use the products only under the supervision of an adult.
- ▶ Use the product only when it is in perfect technical condition.
- ▶ Always retain the instruction manual available near to the product itself.
- ▶ Hand over the product to any third person only together with the present instruction manual.

Fire hazard

Operating the product after wrongly connecting it or bridging certain terminals may trigger a fire or generate smoke. Permanent operation of the components may cause overheat and trigger a fire.

- ▶ Do not use the product without monitoring the process!
- ▶ Immediately disconnect the product from the mains supply if smoke is generated!
- ▶ Operation of components »Stop section« and »Branch-off junction« must not exceed 40 seconds.
- ▶ Operation of component »Parking space« must not exceed 5 seconds.

Corrosion hazard

Using the product in moist rooms or any contact of the product with water may cause property damage.

- ▶ Use only in dry rooms!
- ▶ Avoid any contact with water!

Risk of physical injury and property damage

Improper use of the product may cause physical injury and property damage.

- ▶ Do not open enclosures!
- ▶ If the product does not operate correctly or does not operate at all: Consult FALLER'S Customer Service Department!

Environmentally friendly disposal (WEEE)

Products that are labelled with the symbol of a crossed dustbin may not, at the end of their life span, be disposed of with common household waste, but must be handed over to a collecting point that recycles electrical and electronic equipment. The symbol on the product, in the instruction manual or on the packaging calls the user's attention to such obligation. All materials used are recyclable according to their

marking. When allowing recycling, the reutilization of materials, or any other form of recycling used equipment, you will make a valuable contribution to the protection of our environment. Please enquire from your local authorities which disposal companies are relevant in your vicinity.

- ▶ Please observe the local regulations regarding waste disposal.
- ▶ Please observe the WEEE Directive in the version currently applicable.

3. Branch-off junction, Art. 161677

General view

- Body of Branch-off junction with connecting cables
- Covering with guide wire grooves

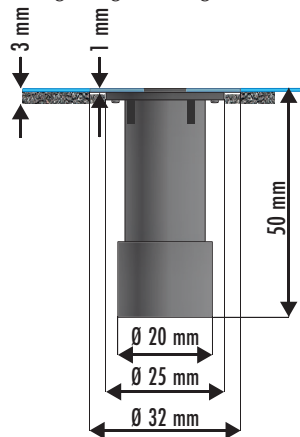


Fig. 1: Side view Branch-off junction

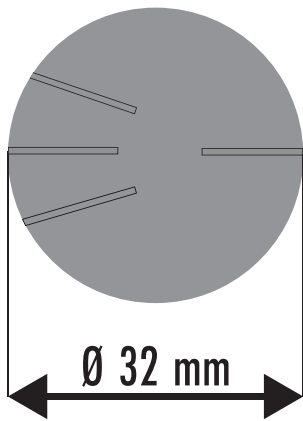


Fig. 2: Covering with guide wire grooves

Mode of operation

Whenever the Branch-off junction is activated its magnetic field pulls the steering slider onto a second wire that turns off. To do this, a polarized iron core is pulled from below in the free space existing between the wires.

Mounting

TIP: Use 3 mm thick poplar plywood to build the roadway. On the one hand that material will allow you to build the Branch-off junction easily and accurately into the surface of the roadway, on the other hand that material is flexible, but sturdy enough for the assembly of your streets and roads.

Method 1 – Flush mounting of the Branch-off junction (recommended method)

Mounting is to be carried out by performing the following procedures:

1. Ideally you will first mill the groove intended for the guide wire running straight (e.g. using the Groove cutter, Art. 161669).
2. Lay the included covering of the Branch-off junction, with the three plastic noses turned downwards, onto the run of guide wire in such a way that both grooves that are in alignment will be lying exactly on the straight run of wire. Using a pencil, mark onto the support the contour as well as the position of the groove that follows the direction desired for the branching off.

3. Remove the covering and mark the centre of the circle.
4. Mill the groove intended for the guide wire that will branch off.
5. Drill a bore with a 28 mm diameter at the centre of the circle.
6. Now join the covering, using two of the three plastic noses, to the body of the Branch-off junction in such a way that the body will be lying exactly below the recess existing between the grooves intended for the incoming and the branching-off guide wire.
7. Using flat nose pliers press the noses so that covering and body will be firmly joined (see Fig. 5). The join is also possible by heating the noses with a hot screw driver or through careful bonding with an instant adhesive gel. Do not use under any circumstances any liquid instant adhesive as the creeping capability of such adhesive might also glue together some parts inside the body of the Branch-off junction, which would make the Branch-off junction unusable.

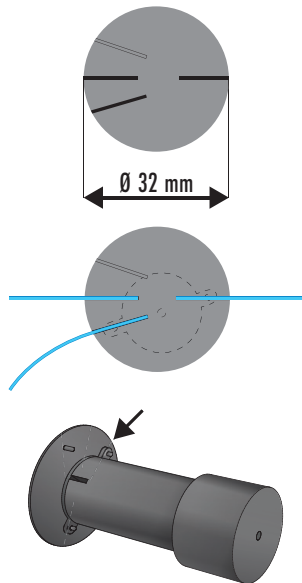
Example: Left-hand turn

Fig. 3: Variant Left-hand turn

Example: Right-hand turn

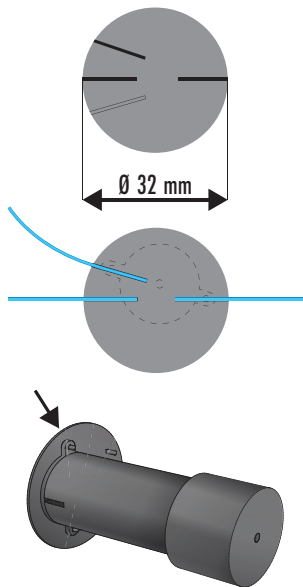


Fig. 4: Variant Right-hand turn

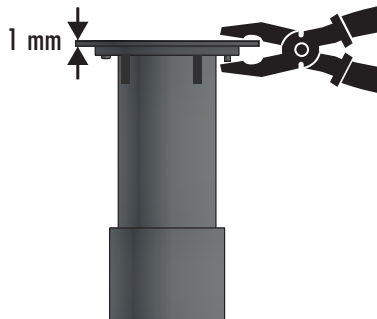


Fig. 5: Pressing the body of the Branch-off junction and the covering together

8. Now insert the assembled Branch-off junction into the bore and check that all grooves of the cover and the guide wire grooves are accurately in alignment.
9. Take the Branch-off junction off again and cut a hollow 1 mm deep over the entire surface area you have marked previously.
10. Insert the assembled Branch-off junction again and check that the grooves are in alignment and the covering is flush with the recess. If

- necessary, re-work the recess until the covering shows a perfect fit.
11. Ideally you will now fix the body protruding downwards with some hot-melt glue or any other suitable glue such as for instance lining glue »Ovalit S« to avoid any ulterior detachment, for instance through unintended contact. Imperatively make sure that no glue enters through the holes of the enclosure.
 12. Now fix the guide wires within the grooves of the Branch-off junction covering with a drop of instant adhesive. Make sure that the guide wires fill the entire length of the grooves.
 13. Finally, complete the roadway surface using FALLER roadway and terrain knifing filler (Art. 180500).
 14. When finishing the roadway surface with roadway paint, imperatively make sure that all guide wires are visible right at the roadway surface and will be covered later through nothing else but the paint.

Method 2 – Staggered mounting of the Branch-off junction (not recommended!)

If the situation on your installation does not allow any flush mounting of the Branch-off junction, you may instead of Method 1 also mount the Branch-off junction at a staggered height and then cover the difference in level with knifing filler. Since that procedure later involves various risks while playing, it is not recommended.

For staggered mounting, first perform steps 1 to 7 described in Method 1 (Flush mounting) and then proceed as follows:

8. Fix the Branch-off junction covering onto the road surface in such a way that the grooves are in alignment with the guide wire.
9. Insert the wire into the grooves and fix it with a drop of instant adhesive. Make sure that the guide wire fills the entire length of the grooves in the covering and features smooth curves at the transitions to and from the covering. Avoid any bends or edges in the run of the guide wire.
10. Ideally you will now fix the body protruding downwards with some hot-melt glue or any other suitable glue such as for instance lining glue »Ovalit S« to avoid any ulterior detach-

- ment, for instance through unintended contact. Imperatively make sure that no glue enters through the holes of the enclosure.
11. Using a spatula apply a thin layer of FALLER roadway and terrain knifing filler (Art. 180500) onto the covering and some more all around. Ensure easy and smooth transitions in particular at the differences in level that have to be compensated.
 12. Prior to finishing the roadway surface with roadway paint, imperatively make sure that all guide wires are visible right at the roadway surface and will be covered later through nothing else but the paint.

Connection

The Branch-off junction must operate on 16 V AC (alternating voltage) at most or 22 V DC (constant voltage). The control modules »Traffic Control« (Art. 161651) and »Traffic Light Control« (Art. 161654) make such a voltage available. At the »Expansion module« (Art. 161352) and the »PC-standard module« (Art. 161351) the Branch-off junction is connected to the 15 V DC port. The voltage of the control modules in its turn is supplied via the Transformer (Art. 180641).

ADVICE: If you are using small vehicle models (e.g. cars or N scale vehicles), you should solder on one of the two supply cables of the Branch-off junction a resistor featuring 82 ohms / 1 watt. This will prevent the Branch-off junction from switching the dry-reed sensor built into the vehicles, and thus from stopping these vehicles every time a vehicle drives over the switched-on Branch-off junction.

Possible connections

To operate the Branch-off junction there are various possible connections to choose from.

Manual operation of the Branch-off junction: To make manual operation of the Branch-off junction possible, connect a supply cable of the Branch-off junction to a 16 V AC output of the transformer and the second supply cable to a push button/switch. In addition connect the push button/switch to the other output of the transformer.

Automatic or computer-based operation of the Branch-off junction: For the proper connection of the Branch-off junction to a control module, see the instructions for use supplied with the relevant product. The supply voltages stated there might slightly differ from those indicated in the present instruction manual.

Manual connection of the Branch-off junction

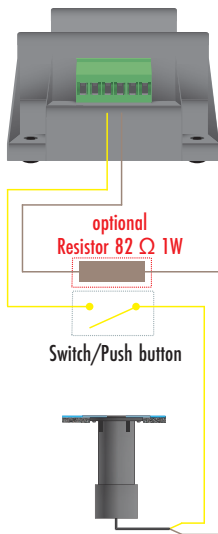


Fig. 6: Connection diagram Branch-off junction, manual operation

Connection of the Branch-off junction to control module »Traffic Control« (Art. 161651)

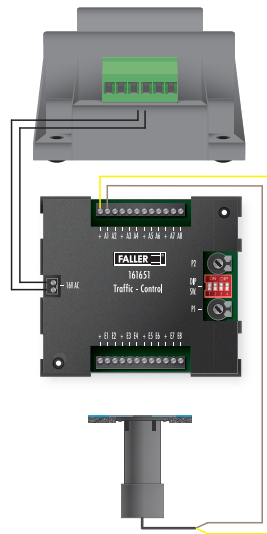


Fig. 7: Connection diagram Branch-off junction / Traffic Control

Connection of the Branch-off junction to the »Expansion module« (Art. 161352)/»PC-standard module« (Art. 161351)

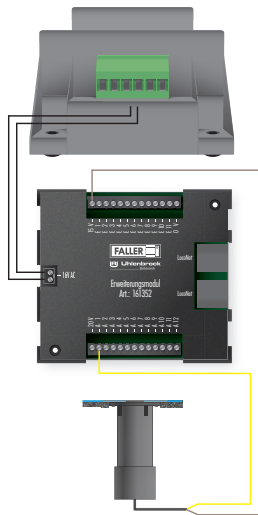


Fig. 8: Connection diagram Branch-off junction / Expansion module / PC-standard module

4. Stop section, Art. 161675

General view

- Magnet coil with connecting cables
- Holding bow with steel core

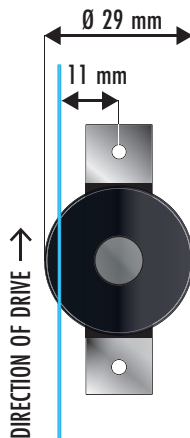


Fig. 9: Stop section with contact wire, Top view

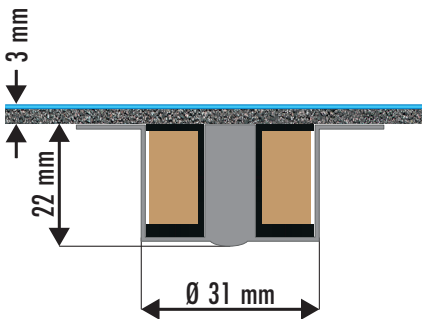


Fig. 10: Stop section, Cross section

Mode of operation

Whenever the Stop section is activated it generates a magnetic field. That magnetic field switches the dry-reed sensor in an analog vehicle or the magnetic field sensor in a digital vehicle and interrupts the current supply to the motor. The vehicle thus stops.

When driving over a Stop section, a digital vehicle can change to a second driving speed if the south pole of the Stop section is showing upwards.

NOTE: Please note that in Car System Digital operation, installing virtual traffic lights or traffic signs replaces to a very large extent the use of Stop sections.

TIP: Use the Stop section only for a brief stop of vehicles. The component suitable for a longer stay of vehicles is the »Parking space« (Art. 161674).

Mounting

When mounting the Stop section, imperatively observe the following data:

- The Stop section is always mounted to the right of the guide wire, when looking in the direction of drive.
- Distance from the centre of the magnet coil to the guide wire: 11 mm (this value might slightly vary when mounting in curves).
- Distance of the Stop section to the roadway surface: 3 mm.

TIP: Use 3 mm thick poplar plywood to build the roadway. On the one hand that material will allow you to keep accurately the imperatively required distance from the Stop section to the surface of the roadway, on the other hand that material is flexible, but sturdy enough for the assembly of your streets and roads.

ADVICES:

- Avoid mounting the Stop section in curves as far as possible! In exceptional cases the following rule is to apply: If vehicles have to stop in a curve to the left, the magnet must be placed slightly nearer to the guide wire, in curves to the right slightly farther away from the wire. Accurate data can only be determined by test runs as the specific values depend on the radius of curves as well as on the length of the vehicles used and on the position of the dry-reed sensors/magnetic field sensors built into them.
- Ideally fix the Stop section directly onto the underside of a 3 mm thick roadway with a suitable adhesive such as for instance lining glue »Ovalit S«.
- Do not fasten the Stop section to the underside of the roadway using screws, even if the bores in the plates suggest that method.
- Align both fastening plates of the holding bow parallel to the guide wire as far as possible.

Carry out the mounting by proceeding as follows:

1. Decide on a position for the Stop section to the right of the guide wire: the distance from the centre of the circular magnet coil to the guide wire must be 11 mm when the guide wire runs straight.
2. Drill a small hole at the centre of the position you have decided on, this will make your orientation easier during the ulterior mounting procedure. It will make it possible for you to detect the centre from the underside of the installation, too.
3. Fastening of the Stop section:
 - If you are using a roadway made of 3 mm thick plywood, you may fasten the Stop section directly under the road, without cutting any recess.
 - If you are using wooden material with a thickness exceeding 3 mm, the diameter of the hole to be mortised is 30 mm to allow you to embed the magnet coil from above into the roadway. Also provide two lateral recesses for the plates of the holding bow and align these parallel to the run of the guide wire, not at a right angle. For your guidance you might want to mark out the approximate direction of run of the guide wire on the underside of your installation. The corresponding recess allowing to house the Stop section including the holding bow is approx. 30 x 55 mm large.

4. Search for the centre of the Stop section by holding the middle of the component near the drilled hole, and fix the plates of the holding bow containing the magnet coil temporarily with instant adhesive or hot-melt glue to the underside of the roadway. On doing so make sure that the plates of the holding bow are as parallel to the guide wire as possible.
5. Finally fix the holding bow to the underside of the roadway using a suitable adhesive, for instance lining glue »Ovalit S«. Avoid fastening the component with screws.

Connection

The Stop section must operate on rectified 16 V alternating voltage. That corresponds to approx. 22 V constant voltage. The various control modules »Traffic Control« (Art. 161651), »Traffic Light Control« (Art. 161654), »PC-standard module« (Art. 161351) and »Expansion module« (Art. 161352) make such a voltage available. The voltage of the control modules in its turn is supplied via the Transformer (Art. 180641).

NOTE:

- If you want to operate the Stop section without using a FALLER control module, you will require a Rectifier (Art. 180633).
- During operation the Stop section requires approx. 160 mA, however in the instant of switching that current may briefly be approx. 10 times as high as that working current. This is why it is not advisable to use other combinations of transformers and rectifiers.
- The magnetic north of a switched-on Stop section must show towards the vehicle, thus show upwards. This is the case if the magnet at the steering slider of the vehicle is repelled by a Stop section that is correctly connected and activated. The polarity of the Stop section can only be checked if the iron core is located in the coil. If the polarity is reversed, simply exchange both connecting cables of the Stop section.

Polarity for a Stop section



Fig. 11: South upwards: In analog Car System operation wrong polarity. In Car System Digital operation shift to slow speed.



Fig. 12: North upwards: Correct polarity.

NOTE: The steering slider should always glide parallel to the road surface.

Possible connections

To operate the Stop section there are various possible connections to choose from.

Manual operation of the Stop section: To operate the Stop section manually, first connect the Rectifier (Art. 180633) to the Transformer (Art. 180641). Then connect a supply cable of the Stop section to a terminal at the Rectifier (e.g. to '+'). The colour of that cable is of no significance. Connect the second supply cable of the Stop section to a wire of a push button/switch and connect its second wire to the second terminal of the Rectifier (e.g. to '-').

Automatic or computer-based operation of the Stop section: For the proper connection of the Stop section to a control module, see the instructions for use supplied with the relevant product. The supply voltages stated there might slightly differ from those indicated in the present instruction manual.

Manual connection of the Stop section

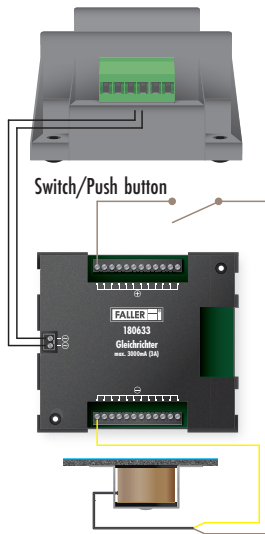


Fig. 13: Connection diagram Stop section, manual operation

Connection of the Stop section to control module »Traffic Control« (Art. 161651)

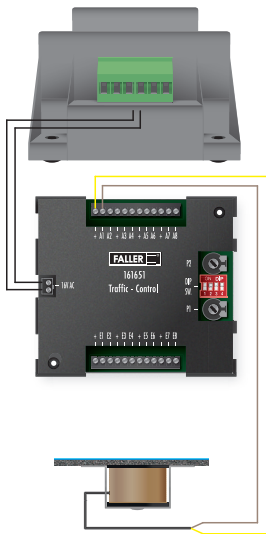


Fig. 14: Connection diagram Stop section / Traffic-Control

Connection of the Stop section to the »Expansion Module« (Art. 161352) / »PC-standard module« (Art. 161351)

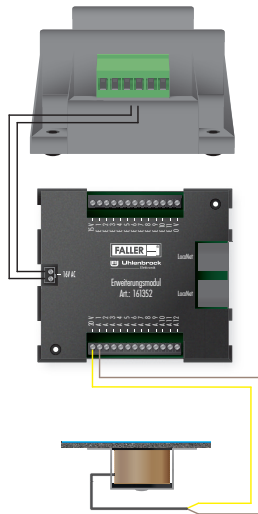


Fig. 15: Connection diagram Stop section / Expansion module / PC-standard module

5. Parking space, Art. 161674

General view

- Body with clearing field coil and variable coil core
- Spacer (covering) with permanent magnet
- Fastening screws

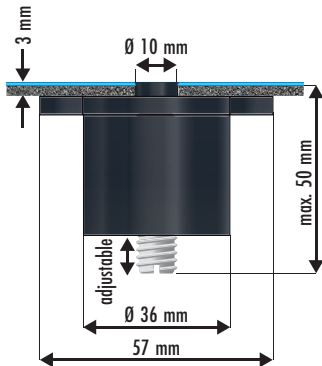


Fig. 16: Parking space, Side view

Mode of operation

In contrast with the component »Stop section« that is only intended for a short stop of your vehicles, the »Parking space« is provided with a permanent magnet that maintains analog vehicles currentless even for a long period of time. That component is thus particularly suitable for stopping and parking the vehicles at the end of playing.

In analog Car System operation a current-operated coil built into the Parking space, when supplied with current, briefly overlays the permanent magnetic field of the Parking space. This switches on the dry-reed sensor located within the stopped analog vehicle and supplies the motor with current. The vehicle is put in motion.

In Car System Digital operation the Parking space puts a digital vehicle in the rest mode after a certain time and switches out its radio link. However, the magnetic field sensor built into the digital vehicle continuously checks whether the Parking space is switched out or not. When the Parking space is switched on, radio transmission is resumed immediately.

Mounting

When mounting the Parking space, imperatively observe the following data:

- The Parking space is always mounted to the right of the guide wire, when looking in the direction of drive.
- Distance from the centre of the body to the guide wire: 14 mm.

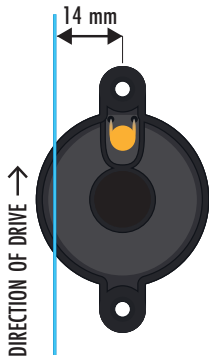


Fig. 17: Parking space with contact wire, Top view

TIP: Use 3 mm thick poplar plywood to build the roadway. On the one hand that material will allow you to build the Parking space easily and accurately into the surface of the roadway, on the other hand that material is flexible, but sturdy enough for the assembly of your streets and roads.

ADVICE: Avoid mounting the Parking space in curves as far as possible since, in such areas, there might readily be some variations of the distance from the guide wire to the dry reed sensor/magnetic field sensor located in the vehicle. You will thus minimize the risk of ulterior faulty operation.

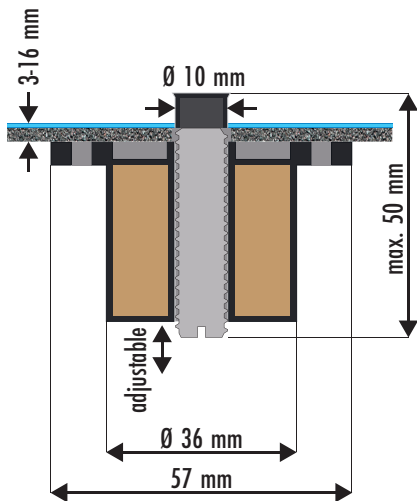


Fig. 18: Parking space, Cross section, elevated spacer

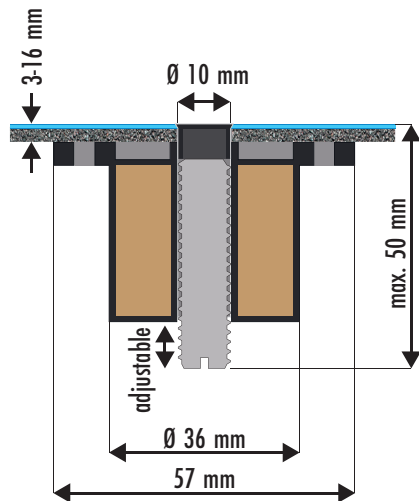


Fig. 19: Parking space, Cross section, flush spacer

Carry out the mounting by proceeding as follows:

1. Decide on a position for the Parking space to the right of the guide wire: the distance from the centre of the variable coil core to the guide wire must be 14 mm.
2. In the place you have decided on drill a hole with a diameter of 10 mm. You will get best results using a wood borer with a brad point (tap borer). After that slightly countersink the bore (90°).
3. Rotate the variable coil core out of the body so that it will protrude a few millimetres.
4. Fix the body under the roadway:
 - if thickness is 3 to 10 mm with glue: Fix the enclosure protruding downwards to the underside of the roadway with some hot-melt glue or any other suitable glue such as for instance lining glue »Ovalit S«. Please make sure that no glue enters through the holes of the enclosure.
 - if thickness is 11 to 16 mm with screws: Fix the enclosure protruding downwards to the underside of the roadway using the fastening screws that are included.
5. Insert the spacer from above into the bore and adjust the coil core by rotating it until the spacer is flush with the roadway surface and the coil core rests against the magnet located in the spacer.

Connection

The Parking space must operate on 16 V alternating voltage or 22 V constant voltage. The various control modules »Traffic Control« (Art. 161651), »Traffic Light Control« (Art. 161654), »PC-standard module« (Art. 161351) and »Expansion module« (Art. 161352) make such a voltage available. The voltage of the control modules in its turn is supplied via the Transformer (Art. 180641).

Possible connections

To operate the Parking space there are various possible connections to choose from.

Manual operation of the Parking space: For manual operation connect a supply cable of the Parking space to a 16 V AC output of the transformer and the second supply cable to a push button/switch. In addition connect the push button/switch to the other port of the 16 V AC output of the transformer.

NOTE: A pulse duration of 1-2 seconds is sufficient to set a car in motion. In case of prolonged actuation the thermocouple in the Parking space will turn off the power supply.

Connection of the Parking space to control module »Traffic Control« (Art. 161651)

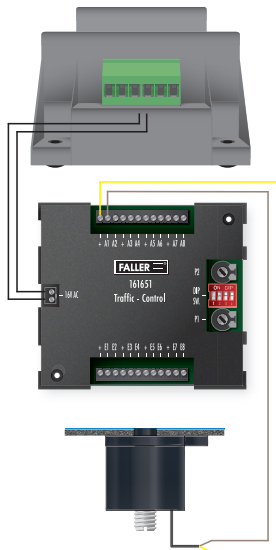


Fig. 21: Connection diagram Parking space / Traffic Control

Connection of the Parking space to the »Expansion module« (Art. 161352) / »PC-standard module« (Art. 161351)

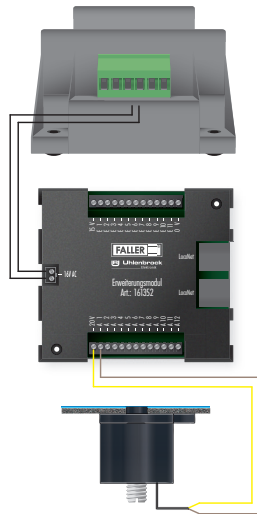


Fig. 22: Connection diagram Parking space / Expansion module / PC-standard module

6. Interesting facts

German, English, French and Dutch Instruction Manuals: You will find the present instruction manual in German, English, French and Dutch to download as pdf file on our website www.faller.de.

Deutsche, Englische, Französische und Niederländische Produktanleitung: Die vorliegende Produktanleitung in deutscher, englischer, französischer und niederländischer Sprache finden Sie als PDF-Download auf www.faller.de.

Instructions produit en allemand, en anglais, en français et en néerlandais: Vous trouverez les présentes instructions produit à télécharger sous forme de fichier au format pdf, en allemand, en anglais, en français et en néerlandais, sur notre site www.faller.de.

Duitse, Engelse, Franse en Nederlandse handleiding: Deze handleiding in het Duits, Engels, Frans en Nederlands vindt u als PDF-download op www.faller.de.

Laser-Street

FALLER Laser-Street will enable you to realize practically any personalized circuit layout. The plug-in road

elements made of 3 mm thick poplar plywood feature a groove accurately mortised using laser technology to hold the guide wire, fore-bores to receive the Sensors and recesses for Branch-off junctions as well as markings for the accurate positioning of Stop sections. Connecting parts at the ends ensure the compatibility and the accurate alignment of all roadway elements.

Groove cutter, Art. 161669

The Groove cutter (Art. 161669) is the ideal aid to mill a perfect slot to hold the guide wire flush with the surface. The keyway cutter is simply moved along the outlined steering track, its lateral brass stop rings ensuring that only so much material as is necessary in depth and width is removed for the guide wire to accurately fit within the groove.

Special contact wire, Art. 161670

To build roadways use only FALLER Special contact wire (Art. 161670), as using magnetic tape or softer iron wires may result in unwanted functional problems. To ensure that traffic flows smoothly without incidents neither the individual magnetic fields of vehicles or control components nor the overall magnetic

field of your model installation should be impaired. Using FALLER Special contact wire will prevent potential malfunction sources in traffic caused by weaker, stronger or permanent local magnetic fields.

Sensors, Art. 161773

Mode of operation: Sensors built into the roadway are activated by magnets fitted to vehicles and timely send a checkback signal to a control unit such as for instance the »Traffic Control« or the »Expansion module«. Such signal is used by the control unit to activate a functional element.

In Car System Digital operation their use is particularly meaningful whenever checkback signals are required from spots that are not covered by Satellites (Art. 161353), but nevertheless should be detected, for instance in underground garages or shadow areas. Other possible uses consist in monitoring traffic at level crossings or controlling intersections when simultaneously operating Car System Digital and the analog Car System.

ADVICE: Avoid mounting Sensors in curves.

Mounting: As a rule Sensors interrupt the course of the guide wire. Their diameter and the corresponding

size of bore is 3 mm. Secure the Sensor within the bore using a drop of instant adhesive. On doing so, position the flat edge of the otherwise circular surface of the Sensor at right angles to the direction of drive (see Fig. 23). Make sure that both ends of the guide wire run right up to the Sensor.

Connection: Sensors are connected to the inputs of a control module.



Fig. 23: Positioning the Sensor surface

Additional magnets

If a given component should not be activated by every vehicle, Sensors may also be installed near the guide wire. Such Sensors are then only activated to send a switching signal by vehicles provided with an additional magnet on their underbody, for instance busses that are approaching a bus stop or lorries that are approaching a transshipment platform.

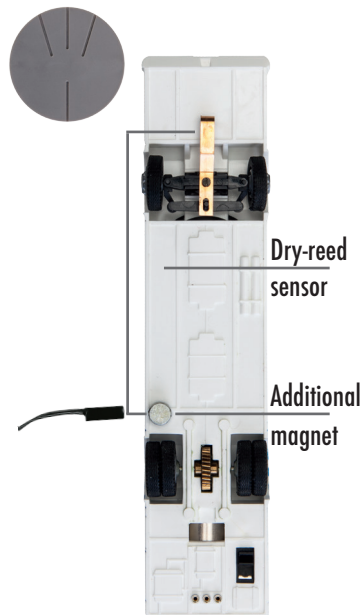


Fig. 24: Additional magnet H0

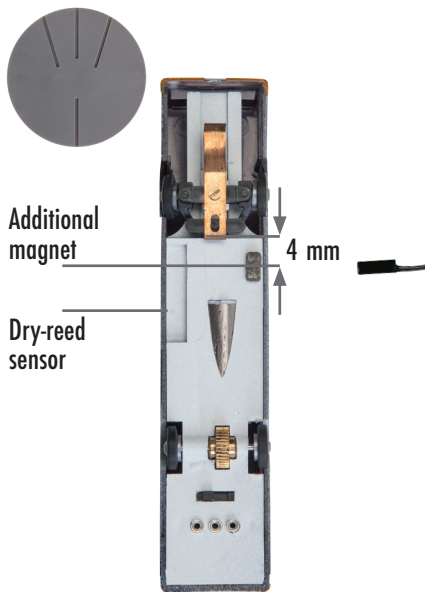


Fig. 25: Additional magnet N

7. Technical data and symbols

Power supply »Branch-off junction«

Designation	Value
Supply voltage	- 16 V AC or 22 V DC. Each time with a resistor. - 15 V DC without resistor
Current consumption	150mA

Tab. 1: Power supply »Branch-off junction«

Power supply »Stop section«

Designation	Value
Supply voltage	22V DC
Current consumption	160mA

Tab. 2: Power supply »Stop section«

Power supply »Parking space«

Designation	Value
Supply voltage	16V AC oder 22V DC
Current consumption	330mA

Tab. 3: Power supply »Parking space«






Rule allowing to calculate the maximum number of active components that can be simultaneously connected to a FALLER Transformer (3000 mA):

Total current consumption = Number of active components x Current consumption

e.g.: 3 Stop sections at 160 mA each + 2 Branch-off junctions at 150 mA each = 780 mA

Advice: Current consumption of a control module: approx. 100 mA

Symbols

Symbol	Meaning
	Product is subject to the European WEEE Directive.
CE	CE conformity label
	1:87/H0/16.5 mm track gauge
	1:160/N/9 mm track gauge
	Prompting
	Note

Tab. 4: Symbols

Your direct line to FALLER's customer service:

Phone + 49 (0) 7723 / 651 106
E-Mail kundendienst@faller.de



Gebr. FALLER GmbH
Kreuzstraße 9
D-78148 Gütenbach
Phone +49 (0) 77 23 / 651-0
Telefax +49 (0) 77 23 / 651-123
www.faller.de
info@faller.de

© Gebr. FALLER GmbH | Sachnr. 161 674 2 | Subject to change | 09.09.2015